

Solemyo

SYKCE

PSY24

CE

Autonomous power system

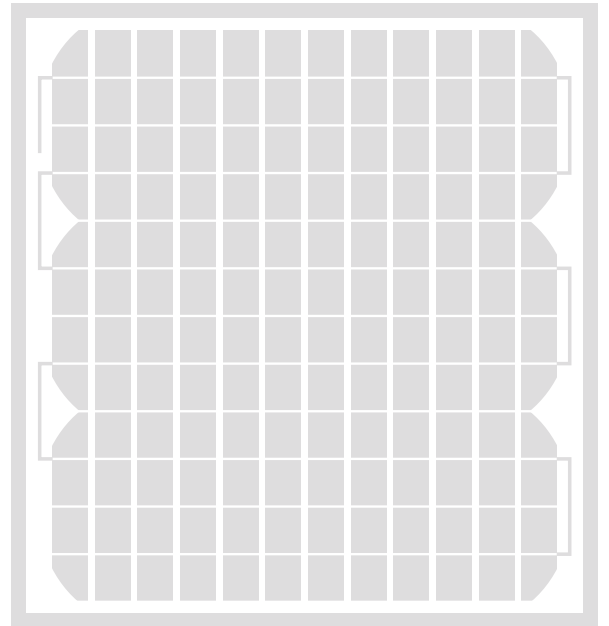

EN - Installation and use instructions and warnings

Nice

EN - Addendum to the manual Solemyo

IT - Addendum al manuale Solemyo

FR - Addendum au manuel Solemyo

ES - Addendum al manual Solemyo

DE - Nachtrag zur Anleitung Solemyo

PL - Załącznik do instrukcji Solemyo

NL - Addendum bij de handleiding Solemyo

Nice

ENGLISH-CAUTION!

- When the **automation** is powered by the “Solemyo” system, it **MUST NOT BE POWERED** at the same time from the electrical mains.
- When the **accumulator** is being recharged (from the photovoltaic panel or from battery charge), the red LED emits 2 short flashes every 5 seconds. After installation, ensure that this signal is present when the panel is illuminated by the sun.
- **NEVER leave the battery connected to the automation if the photovoltaic panel is not connected and fully operative.** *If the battery is not sufficiently charged, the reserve will only last a few days.*
- If the automation is not used for prolonged periods, detach the connectors of the automation and photovoltaic panel from the battery and store the latter in a cool and dry location.

ITALIANO – ATTENZIONE!

- Quando l'**automazione** viene alimentata dal sistema “Solemyo”, questa **NON DEVE ESSERE ALIMENTATA** contemporaneamente anche dalla rete elettrica.
- Quando l'**accumulatore** è in ricarica (da pannello fotovoltaico o da carica batteria), il Led rosso emette 2 brevi lampeggi ogni 5 secondi. Verificare che questa segnalazione sia presente anche dopo l'installazione, quando il pannello è illuminato dal sole.
- **Non lasciare MAI collegato l'accumulatore all'automatismo se non è anche collegato e correttamente funzionante il pannello fotovoltaico.** *Se l'accumulatore non è adeguatamente ricaricato, esaurisce la sua riserva entro pochi giorni.*
- Se l'automazione non viene usata per lunghi periodi si consiglia di scollegare i connettori dell'automatismo e del pannello fotovoltaico dall'accumulatore e di custodire questo in un luogo fresco e asciutto.

FRANÇAIS – ATTENTION !

- Quand l'**automatisme** est alimenté par le système « Solemyo », il **NE DOIT PAS ÊTRE ALIMENTÉ** simultanément aussi par le secteur électrique.
- Quand l'**accumulateur** est en recharge (par le panneau photovoltaïque ou par le chargeur de batterie), la Led rouge émet 2 clignotements brefs toutes les 5 secondes. Vérifier que cette signalisation est présente aussi après l'installation, quand le panneau est éclairé par le soleil.
- **Ne JAMAIS laisser l'accumulateur connecté à l'automatisme si le panneau photovoltaïque n'est pas lui même connecté et en parfait état de fonctionnement.** *Si l'accumulateur n'est pas correctement rechargé, il épuise sa réserve en quelques jours.*
- Si l'automatisme n'est pas utilisé pendant de longues périodes, il est conseillé de débrancher les connecteurs de l'automatisme et du panneau photovoltaïque de l'accumulateur et de remiser l'accumulateur dans un endroit frais et sec.

ESPAÑOL – ¡ATENCIÓN!

- Cuando el **automatismo** está alimentado por el sistema “Solemyo”, **NO DEBE ESTAR ALIMENTADO** simultáneamente por la red eléctrica.
- Cuando el **acumulador** se esté recargando (desde el panel fotovoltaico o desde el cargador de batería), el Led rojo emitirá 2 destellos breves cada 5 segundos. Incluso después de la instalación, controle que dicha señalización esté presente cuando el panel esté iluminado por el sol.

- **NUNCA deje conectado el acumulador al automatismo si no estuviera también conectado el panel fotovoltaico y que funcione correctamente.** *Si el acumulador no estuviera bien recargado, agotará su reserva de energía en pocos días.*
- Si el automatismo no se utilizara por mucho tiempo, se aconseja desconectar los conectores del automatismo y del panel fotovoltaico del acumulador y guardar este último en un lugar fresco y seco.

DEUTSCH – ACHTUNG!

- Wenn die **Automatisierung** durch das System „Solemyo“ gespeist wird, darf sie **NICHT GLEICHZEITIG** auch durch das Stromnetz gespeist werden.
- Wenn der **Speicher** geladen wird (durch Kollektor oder durch Batterieladegerät), blinkt die rote Led alle 5 Sekunden 2 Mal kurz auf. Prüfen, ob diese Signalisierung auch nach der Installation vorliegt, wenn der Kollektor von der Sonne bestrahlt wird.
- **Den Speicher NIE mit der Automatisierung verbunden lassen, wenn nicht auch der Photovoltaikkollektor angeschlossen ist und korrekt funktioniert.** *Wenn der Speicher nicht ausreichend aufgeladen ist, hält seine Reserve nur wenige Tage an.*
- Wenn die Automatisierung längere Zeit nicht benutzt wird, werden die Stecker der Automatisierung und des Photovoltaikkollektors vom Speicher getrennt und dieser an einem kühlen und trockenen Ort aufbewahrt.

POLSKI – UWAGA!

- Podczas, kiedy **automatyka** jest zasilana przez system “Solemyo”, nie **MOŻE ONA BYĆ** jednocześnie **ZASILANA** również z sieci elektrycznej.
- Podczas, kiedy **bateria** jest doładowywana (z panelu fotoelektrycznego lub z prostownika), czerwona dioda wykona 2 krótkie błyski co 5 sekund. Po zamontowaniu należy sprawdzić, czy ta sygnalizacja jest widoczna w przypadku, kiedy panel jest oświetlany przez słońce.
- **Nie zostawiać NIGDY akumulatora podłączonego do automatu, jeżeli panel fotoelektryczny nie jest podłączony i nie funkcjonuje prawidłowo.** *Jeżeli akumulator nie jest odpowiednio naładowany wyczerpuje swój zapas energii w ciągu kilku godzin.*
- Jeżeli automat nie będzie używany przez dłuższy okres czasu zaleca się rozłączyć złącza automatu oraz panelu fotoelektrycznego od akumulatora i przechowywać je w miejscu chłodnym i suchym.

NEDERLANDS – LET OP!

- Wanneer de **automatisering** van stroom wordt voorzien door het systeem “Solemyo”, mag deze **NIET TEGELIJKERTIJD OOK GEVOED** worden door het elektriciteitsnet.
- Wanneer de **accumulator** aan het opladen is (via zonnepaneel of oplader), zal de rode led iedere 5 seconden 2 maal kort knipperen. Controleer of deze signalering ook na de installatie, wanneer het paneel verlicht wordt door de zon, aanwezig is.
- **Laat de accumulator NOOIT aangesloten op de automatisering als niet ook het zonnepaneel aangesloten is en correct werkt.** *Als de accumulator niet goed wordt opgeladen, zal zijn energie-reserve binnen enkele dagen opraken.*
- Als de automatisering voor lange tijd niet gebruikt zal worden, wordt aanbevelen de connectors van de automatisering en van het zonnepaneel los te maken van de accumulator en de accumulator op een koele en droge plaats te bewaren.

• **Products compatible with SYKCE:**

CAUTION! – Efficient use of the SYKCE kit can only be guaranteed in combination with the products listed below. Use with products not specifically envisaged herein, even if technically feasible, is not recommended due to the low number of daily cycles obtainable. The list of products is based on the date of printing as stated in this addendum; check for any updates on the web site "www.niceforyou.com".

- **MC824H:** with motors TO4024, TO5024, TO7024, MB4024, MB5024, ME3024, HY7024
- **Robus:** RB600/B, RB600P/B, RB1000/B, RB1000P/B (the "/A" versions are compatible but with lower performance)
- **Soon:** SO2000/A
- **Spin:** SPIN23KCE
- **Pop:** POPKCE/A
- **Ten:** TN2010/A, TN2010/A + TN2020
- **Wingo + MC424:** WINGO2024KCE, WINGO3524KCE
- **X-BAR:** X-BAR

• **To calculate the maximum number of cycles daily performed by the automation:**

- 01.** In graphs **A, B** or **C** (chapter 3 – instruction manual), read the "**Base coefficient (Cb)**" for the required period of the year.
- 02.** Depending on the type of automation installed and the programmed standby level, refer to **Table 1** to read value "**B**"; add this value to the value "**B**" of any accessories installed.
- 03.** Subtract "**B**" from "**Cb**" to obtain the value "**Y**" ($Y = Cb - B$).
- 04.** Depending on the type of automation installed and weight of the gate leaf, refer to **Table 1** to read value "**K**"; add this value to the value "**K**" of any accessories installed.
- 05.** Read value "**s**"; **s** = duration of a complete cycle (*Opening + Closing*) of the specific automation, measured in seconds.
- 06.** Multiply "**K**" by "**s**" to obtain the value "**Ks**" ($Ks = K \times s$).
- 07.** On the graph of **fig. 1**, trace the curve corresponding to the value "**Ks**" calculated above. Trace intermediate curves for any intermediate values.
- 08.** Starting from the value "**Y**" calculated above, trace a vertical line that intersects the curve of the value "**Ks**".
- 09.** From the point found, trace a horizontal line that intersects the line of the values of cycles/day. **The result is the maximum number of cycles daily performed by the automation.**

Our example (see fig.1): Automation installed: RB1000/B; Required period of the year: **Cb** = 6; Type of standby: safeties **B** = 0,9 + accessory (1 MOFB photocell) **B** = 0,7. Total **B** = 1,6 - **Y**: ($Y = Cb - B$) $6 - 1,6 = 4,4$; **K** (lightweight leaf) = 4 + accessory (1 Lucy B flashing light) **K** = 1. Total **K** = 5 - **Ks**: "**s**" lasts 40 seconds ($Ks = K \times s$) $5 \times 40 = 200$; **Maximum possible number of cycles per day** = 45.

CAUTION! – To ensure optimal efficiency of the Solemyo system, the control unit must be programmed with the "StandBy" function on level "all". For further details, please refer to the control unit instruction manual and to the programmable function list with O-view (available at the Internet site www.nice-service.com). **Function can only be enabled with Oview programmer (*)**.

Product	Standby level				Leaf type/imbalance		
	none	safeties	bluebus(*)	all(*)	light	medium	heavy
MC824H	B = 1,2	B = 1	B = 0,8	B = 0	K = 2	K = 4	K = 6
Robus RB600/B	B = 1	B = 0,9	B = 0,7	B = 0,1	K = 3	K = 5	K = 7
Robus RB1000/B	B = 1	B = 0,9	B = 0,7	B = 0,1	K = 4	K = 7	K = 10
Soon SO2000/A	B = 2,5	B = 2	B = 0,8	B = 0,3	K = 5	K = 8	K = 12
Spin SPIN23KCE	B = 0,7	B = 0,6	B = 0,5	B = 0	K = 2	K = 4	K = 6
Pop POPKCE/A	B = 0,7	-	-	B = 0,1	K = 2	K = 4	K = 6
Ten TN2010/A	B = 2,5	B = 2	B = 0,8	B = 0,3	K = 3	K = 4	K = 5
Ten TN2010/A + TN2010	B = 2,5	B = 2	B = 0,8	B = 0,3	K = 5	K = 7	K = 9
WINGO...24KCE	B = 0,7	-	-	B = 0,1	K = 2	K = 4	K = 6
X-BAR	B = 2,5	B = 2	B = 0,8	B = 0,3	K = 3	K = 4	K = 5
Accessories: Consumption levels connected with the presence of devices on the SCA output have not been taken into consideration.							
SMXI / OXI	B = 0,7	B = 0,7	B = 0,7	B = 0,7	K = 0	K = 0	K = 0
MOF / MOFB	B = 1,4	B = 0,7	B = 0	B = 0	K = 0	K = 0	K = 0
MOMB	B = 3,2	B = 3,2	B = 0	B = 0	K = 0	K = 0	K = 0
MOTB	B = 2	B = 2	B = 0	B = 0	K = 0	K = 0	K = 0
Lucy B	B = 0	B = 0	B = 0	B = 0	K = 1	K = 1	K = 1
Oview	B = 0,7	B = 0,7	B = 0,7	B = 0	K = 0	K = 0	K = 0

Solar power kit

- EN - Addendum to the manual
- IT - Addendum al manuale
- FR - Addendum au manuel
- ES - Addendum al manual
- DE - Nachtrag zur Anleitung
- PL - Załącznik do instrukcji
- NL - Addendum bij de handleiding

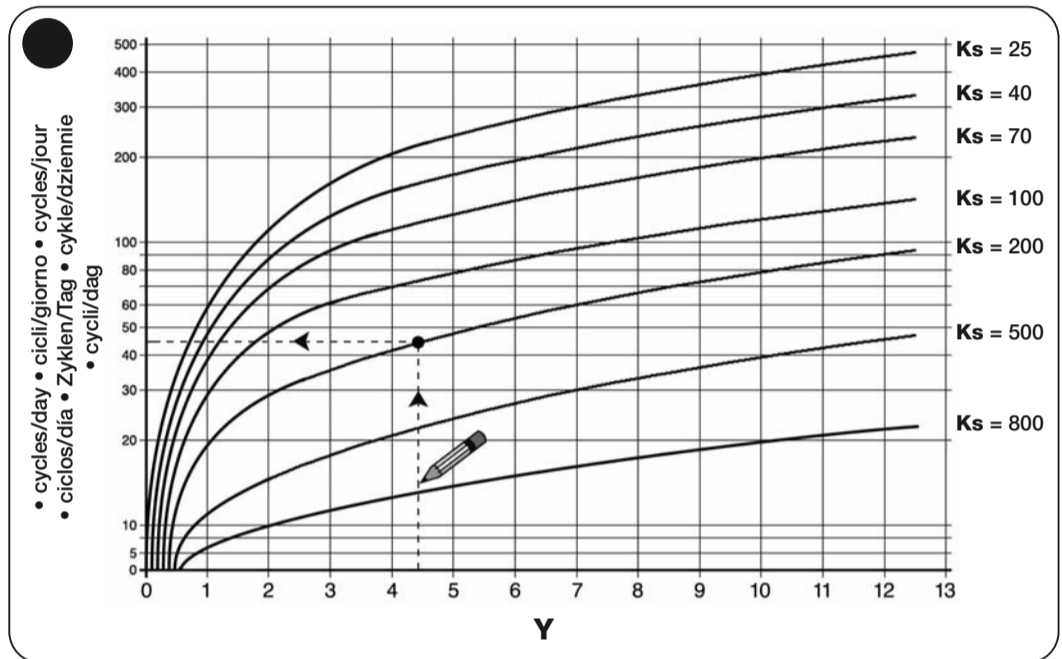

GENERAL SAFETY WARNINGS AND PRECAUTIONS

The design and manufacture of the devices making up the Solemyo system and the information in this manual fully comply with current standards governing safety. However, incorrect installation or programming may cause serious physical injury to those working on or using the system. For this reason, during installation, always strictly observe all instructions in this manual.

If in any doubt regarding installation, do not proceed and contact the Nice Technical Assistance for clarifications.

WORKING IN SAFETY!

Warning – for personal safety it is important to observe these instructions.

Warning – Important safety instructions: keep these instructions in a safe place.

Observe the following warnings:

- make electrical connections exclusively as envisaged in this manual incorrect: connections could cause serious damage to the system.
- If the power cable in the pack is used outdoors, it must be entirely protected with special ducting suitable for the protection of electric cables.
- never touch metal parts of the sockets on the battery casing with metal objects.

Considering the risk situations that may arise during installation phases and use of the system, the devices supplied in the pack must be installed in observance of the following warnings:

- never make any modifications to part of the devices other than those specified in this manual. Operations other than as specified can cause malfunctions. The manufacturer declines all liability for damage caused by makeshift modifications to the devices.
- never place devices near to sources of heat and never expose to naked flames. This may damage system components and cause malfunctions, fire or hazardous situations.
- ensure that the devices cannot come into contact with water or other liquids. During installation ensure that no liquids penetrate the devices present.
- the device packaging material must be disposed of in full observance of current local legislation governing waste disposal.

Warning! – Keep this manual in a safe place to enable future device maintenance and disposal procedures.

1 – Description and intended use

SOLEMYO is an autonomous power system designed for Nice automations for gates and garage doors (the list of compatible automations is provided on the sheet in the product pack and can also be consulted on the website www.niceforyou.com).

Any other use is to be considered improper! The manufacturer declines all liability for damage resulting from improper use of the various devices of the system and other than as specified in this manual.

The Solemyo system is particularly suitable for power supply to automations located far from the fixed power mains.

It comprises 3 standard devices, the combination of which enables different configurations, able to store solar energy or electrical mains energy for use when required by the automation on which the system is installed.

The various system devices are available in the following packs:

- **PSY24**: the core of the system. This device can store electrical energy produced by SYP during the hours of sunlight, making it available at any time of day, including days with adverse weather conditions. The same device can also store energy from the fixed electrical mains, via SYA1. The pack contains the PSY24 battery, cables, connectors for automation connections, fixing hardware and this manual;

- **SYP**: this is a device able to convert sunlight directly into electrical energy. The pack contains a SYP photovoltaic panel, for recharging PSY24, and fixing hardware;

- **SYKCE**: this is a complete kit for autonomous photovoltaic power supply. The pack contains the PSY24 and SYP devices, cables, connectors for automation connections, fixing hardware and this manual;

- **SYA1**: this device enables periodic or emergency recharging of PSY24 via the electrical mains in a protected environment. The pack contains a SYA1 battery charger.

2 – Preliminary installation checks

To ascertain suitability of the system with respect to the specific features of the automation to be powered, the following checks should be performed as well as a check for compliance of the technical data in the chapter "**Technical characteristics**".

In the vicinity of the automation to be powered, locate the ideal point for installation of the photovoltaic panel and the location for the battery, taking into consideration the following restraints:

- a) the application limits specified in this chapter;
 - b) the maximum length of the power cable (3 m) and the cable of the photovoltaic panel (3 m);
 - c) the space available in the vicinity of the automation to be powered.
- Also check the following:
- d) ensure that the selected surfaces for installation of the two devices are solid and guarantee a stable fixture.
 - e) ensure that each device to be installed is in a sheltered location and protected against the risk of accidental impact.
 - f) in particular, for each device ensure the following:

SYP photovoltaic panel

– ensure that the selected panel installation site guarantees 100% direct exposure to sunlight (full sun) every day of the year.

– ensure that the selected panel installation site is far from vegetation, walls or other situations that may create shade, even partial, on the sensitive surfaces of the panel.

Caution! – this surface must be exposed to direct sunlight in all points; partial shade, even if small in size (for example caused by a leaf or other object) will significantly reduce the power capacity of the panel.

– check the possibility of correctly positioning and inclining the panel, with reference to the technical instructions in Chapter 4.

PSY24 battery

To ensure optimal efficiency of the battery and prolonged battery lifetime, it should be installed in a location – in the vicinity of the automation to be powered – protected against high summer temperatures and low winter temperatures.

In fact the **battery charge performance** depends on the ambient temperature where the battery is installed: optimal efficiency is obtained at medium temperatures, while efficiency is considerably reduced at low temperatures.

On the other hand, **battery lifetime** is influenced above all by high sum-

mer temperatures, which accelerate part ageing. Normally the battery average lifetime is approx. 4-5 years; this also depends on the intensity of automation use.

SYA1 battery charger

Refer to the specific chapter in device instruction manual.

3 – System application limits

VERY IMPORTANT:

- When the automation is powered by the “Solemyo” system, **it must never be connected or powered simultaneously** by the electrical mains.
- The devices SYP and SYA1, which supply energy to PSY24, are alternatives and cannot be used simultaneously.

• for photovoltaic power supply (with SYP)

Graphs A, B and C indicate the solar power available, on the basis of the location's latitude, at all times of the calendar year, with the automation powered exclusively using PSY24 and SYP devices. The graph curve is generated taking into account the quantity of daylight recorded at a specific latitude within a year.

To obtain the maximum possible number of cycles per day, proceed as follows:

01. On graph A, B or C (depending on the latitude of your system) identify the period of the year concerned, then locate value “Cb” on the vertical axis, corresponding to this period, as shown in the example in the graph.
02. Then use value “Cb” to make the calculations as stated in the sheet in the product pack.

Warning – During the day, if the photovoltaic panel remains in the shade for a certain period of the day (in particular from 10 am to 2 pm) the maximum possible number of operating cycles decreases in proportion to the hours without panel exposure to sunlight.

Warning – To increase the maximum possible number of cycles per day, automation consumption must be reduced. For this reason, the “Standby” function must be programmed on the automation control units, setting the most efficient level (refer to the automation instruction manual).

• for mains power supply (with SYA1)

The PSY24 battery must be recharged via the mains in a protected environment, previously detaching PSY24 from the SYP solar panel and the automation.

GRAPH A - For countries 45° **NORTH** of the Equator

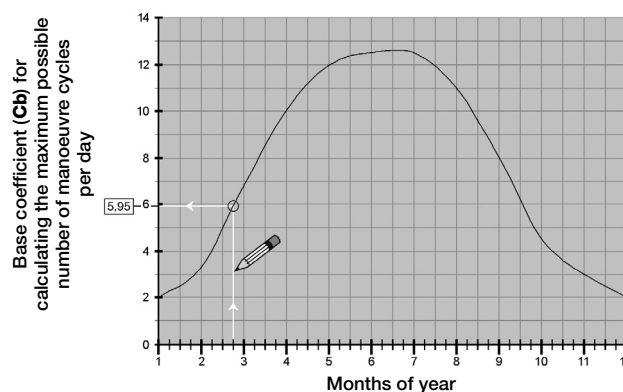

GRAPH B - For countries 45° **SOUTH** of the Equator

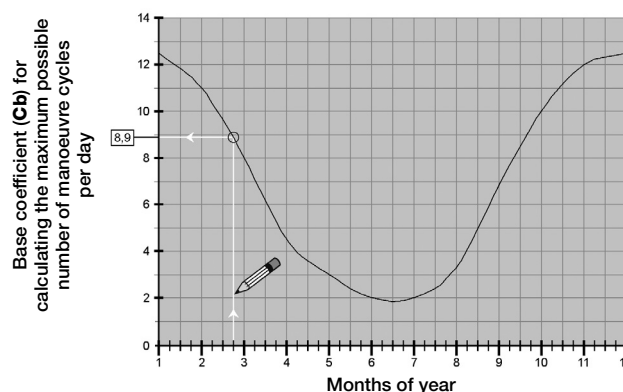

GRAPH C - For countries on the Equator

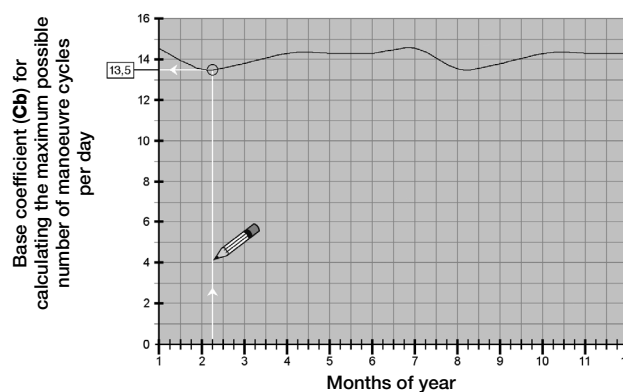
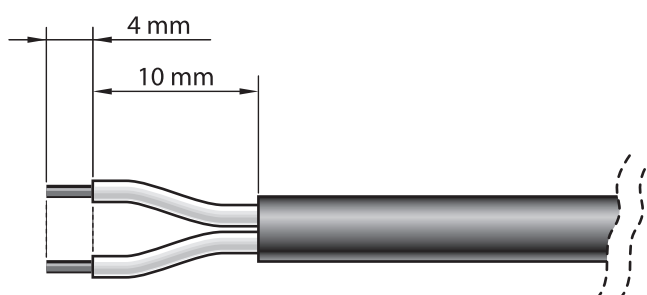

Fig. A



4 – Component assembly and connections

STEP 1 – SYP Optimal photovoltaic panel positioning

As a general rule, the panel must be positioned so that it can be constantly illuminated by sunlight during the day and throughout the year. This means that its horizontal position and vertical angle must be calculated precisely on the basis of the location where it is to be installed.

Therefore, after performing the checks specified in chapter 2, and considering the various options for panel installation as shown in **fig. 6**, proceed as follows:

• **Ensure the correct position of the panel on the horizontal plane** as follows:

a) In the installation site, determine the cardinal points **NORTH** and **SOUTH**, with the aid of a compass or a geographical map of the location.

b) Then position the panel in the direction **NORTH** or **SOUTH**, according to the following:

– if the installation site is **in a country North of the equator** (United States; Europe; Russia; etc.) the panel must be positioned **exactly SOUTH**;

– if the installation site is **in a country South of the equator** (Latin America; Australia; Indonesia, etc.) the panel must be positioned **exactly NORTH**.

For further information, refer to **fig. 4**.

• **Ensure the correct position of the panel on the vertical plane** as follows:

Considering the fact that maximum efficiency of the panel is also required in the winter period, i.e. when the daily hours of sunlight are fewer than in the Summer, the panel should be positioned at an angle that receives the sun rays at right angles (frontal) to the sensitive surface.

This angle corresponds to the latitude of the location and can be read on any commercial geographical map. For example, Madrid has a latitude of 40°; Venice 45°; or London approx 50° etc. For further information, refer to **fig. 5**.

STEP 2 – Fixing the SYP photovoltaic panel in the selected site

After establishing the precise position of the panel, fit all components of the support bracket according to the instructions in **fig. 3**.

Then fix the panel bracket to the selected surface as shown in **fig. 6**.

STEP 3 – Fixing the PSY24 battery in the selected site

After performing the checks specified in chapter 2 establishing the precise position for the battery, fix the latter onto the selected surface as shown in **fig. 13**. **Note** – For fixture, use two screws on the underside, only if the battery is to be secured in a fixed position and not removable.

STEP 4 – Cable routing

IMPORTANT! – If the power cable in the pack is used outdoors, it must be entirely protected with special ducting suitable for the protection of electric cables.

After fixing the panel and battery, route the panel cable through the tube or protection ducting through to the battery.

With reference to the instruction manual of the automation to be powered, remove the control unit protection cover. Then pass the end of the power cable (with wires stripped) through the automation (where the other cables are routed) and through the dedicated cable clamp. Then route the cable through the protection ducting (if present) through to the battery.

Caution! – Do not connect the power cable to the control unit; leave access to the control unit open and leave the cable clamp loose.

STEP 5 – Assembly of “L” socket on the SYP photovoltaic panel cable

If the cable is too long, it can be shortened, taking care to strip the wires so that their length is equal to the values specified in the **fig. A** (**caution!** – different lengths may impair subsequent assembly of the socket).

Then proceed with assembly of the **GREY** “L” type socket on the end of the panel cable, as follows:

01. Insert the various elements of the socket on the cable, taking care to observe the sequence as shown in **fig. 7**;

CAUTION! – Do not modify the electric jumper on the connector (**fig. 8**).

02. Using a slotted screwdriver, attach the **blue wire to terminal n° 1** on the connector and **brown wire to the earthing terminal (4)** (**fig. 9**):

Note – The reference numbers and symbols are printed on the connector below the terminals and on the opposite side.

03. After fixing the two wires, insert the connector in its casing (**fig. 10**).

Important – The correct position of the connector is that with the earthing symbol in the lower position (see **fig. 10**);

04. Then pull the cable outwards from the socket and insert the seal and washer (**fig. 11-a-b**). Lastly, tighten the cable clamp (**fig. 11-c**) using a wrench, to guarantee completely sealed closure.

05. After assembling the socket, position the seal supplied on the connection side (**fig. 12**).

STEP 6 – Assembly of “L” socket on the power cable

If the cable is too long, it can be shortened, taking care to strip the wires so that their length is equal to the values specified in the **fig. A** (**Caution!** – different lengths may impair subsequent assembly of the socket).

Then proceed with assembly of the **BLACK** “L” type socket on the end of the power cable, as follows:

01. Insert the various elements of the socket on the cable, taking care to observe the sequence as shown in **fig. 7**;

CAUTION! – Do not modify the electric jumper on the connector (**fig. 8**).

02. Using a slotted screwdriver, attach the **blue wire to terminal n° 1** on the connector and the **brown wire to the earthing terminal (4)** (**fig. 9**):

Note – The reference numbers and symbols are printed on the connector below the terminals and on the opposite side.

03. After fixing the two wires, insert the connector in its casing (**fig. 10**).

Important – The correct position of the connector is that with the earthing symbol in the lower position (see **fig. 10**);

04. Then pull the cable outwards from the socket and insert the seal and washer (**fig. 11-a-b**). Lastly, tighten the cable clamp (**fig. 11-c**) using a wrench, to guarantee a completely sealed closure.

05. After assembling the socket, position the seal supplied on the connection side (**fig. 12**).

STEP 7 – Connecting the SYP photovoltaic panel to the PSY24 battery

To connect the panel to the battery, proceed as follows:

01. Connect the **GREY** “L” type socket to the “**IN**” connector on the battery (**fig. 14**);

02. To select the most suitable connection configuration for the connection of all system devices, refer to the example shown in **fig. 15**. **Note** – If frequent disconnection of the battery plug is envisaged, use the screw in **fig. 16-a**. Otherwise use the screw in **fig. 16-b**.

STEP 8 – Connecting the PSY24 battery to the automation

CAUTION! – For safety reasons, the operations described in **Step 8** must be performed exclusively by a skilled and qualified technician.

To connect the battery to the automation, proceed as follows:

01. Access the control unit of the automation and insert the power cable connector in the buffer battery socket on the control unit. *To locate this socket, refer to the instruction manual of the automation to be powered.*

02. Connect the **BLACK** “L” type socket to the **OUT** connector on the battery (**fig. 17**);

03. Fix the socket by means of the safety screws supplied, with reference to **fig. 18**. **Note** – If frequent disconnection of the connector from the battery is envisaged, use the screw in **fig. 16-a**. Otherwise use the screw in **fig. 16-b**.

5 – General notes on system use

In general, when the PSY24 battery is not sufficiently charged, the energy reserve will run out in a few days. For this reason, after installation and connecting the product to the automation, the system may not be operative immediately (this depends on the fact that the battery may be discharged due to the natural process of discharging over time, even when stored).

The PSY24 battery enables a finite number of automation manoeuvre cycles (refer to the information sheet in the pack). Therefore, if not constantly recharged using SYP or occasionally by means of SYA1, the *battery low* signal may be activated, with sequential flashing of the Led and a series of *beeps* (this signal may be temporary or permanent).

In particular, when powered by SYP, recharging may be influenced by atmospheric conditions, or intense use of the automation (when the maximum admissible number of manoeuvre cycles is exceeded). When this occurs, PSY24 may indicate the *battery low* status.

PSY24 charging can be restored in one of the following ways:

- A)** - By limiting use of the automation until lighting conditions improve to enable the battery to recharge naturally, via the connection to the SYP photovoltaic panel.
To accelerate the recharging process, disconnect PSY24 from the automation control unit and wait for a few days to enable the SYP photovoltaic panel to store sufficient solar energy to recharge the PSY24 battery.
- B)** - Disconnect the PSY24 battery from the automation control unit and the SYP solar panel (if present). Then recharge PSY24 using the SYA1 battery charger connected to the mains in a protected environment.

When the PSY24 battery is recharging (via the SYP photovoltaic panel or SYA1 battery charger) the red led emits 2 short flashes every 5 seconds. Therefore check that this signal is present, also after installation, when the panel is exposed to the sunlight.

The “*battery low*” warning signal is cleared when the system reaches sufficient electrical autonomy to enable automation operation.

If the automation is not used for extended periods, disconnect the automation and photovoltaic panel connectors from the battery, and store the latter in a cool and dry location.

WHAT TO DO IF... (troubleshooting guide)

- **The automation control unit does not turn on and the PSY24 battery does not supply any signal.**

This may depend on incorrect connections or electrical wiring not fully inserted; otherwise the PSY24 battery may be completely discharged, without sufficient energy to indicate the *battery low* status.

In this case, follow the quick recharging procedure, using the SYA1 battery charger, or wait until the SYP photovoltaic panel, correctly connected, starts to recharge the PSY24 battery.

- **The PSY24 battery tends to discharge too quickly.**

This may be due to excessive ageing of the battery, in which case replacement is recommended; otherwise it may be due to excessively intensive use of the automation, over the application limits envisaged in this manual, found in Chapter 3.

- **The PSY24 battery no longer recharges.**

This may be due to a malfunction of the SYP photovoltaic panel caused by incorrect installation, incorrect cable connections, or malfunction of the PSY24 battery.

PERIODIC MAINTENANCE OPERATIONS

In general, these devices do not require special maintenance; however, regular checks over time will ensure system efficiency.

Therefore, to ensure correct maintenance, check every 6 months that the SYP photovoltaic panel has not accumulated dirt (leaves, sand, etc.) as this may reduce efficiency.

Also check whether PSY24 battery replacement is required, as the ageing process reduces autonomy over time.

CAUTION – The PSY24 battery must be replaced exclusively by skilled and qualified personnel.

DISPOSAL

System device disposal

These devices are an integral part of the automation and therefore must be disposed together with the latter.

As in installation, also at the end of lifetime of these devices, the disassembly and scrapping operations must be performed by qualified personnel.

These devices comprise various types of materials: some of which can be recycled while others must be scrapped. Seek information on the recycling and disposal systems envisaged by the local regulations in your area for the relative device category.

Caution! – some parts of these devices may contain polluting or hazardous substances which, if disposed of into the environment, may cause serious damage to the environment or physical health.

As indicated by the symbol alongside, disposal of these devices in domestic waste is strictly prohibited. Separate the waste into categories for disposal, according to the methods envisaged by current legislation in your area, or return the devices to the retailer when purchasing new equivalent versions.



Caution! – local legislation may envisage serious fines in the event of abusive disposal of these devices.

PSY24 Battery disposal

Caution! – The battery contains pollutant substances; after removing, never dispose of as standard waste. Dispose of or recycle according to current local standards.

TECHNICAL SPECIFICATIONS

WARNINGS: • All technical specifications stated herein refer to an ambient temperature of 20°C (± 5°C) • Nice S.p.a. reserves the right to apply modifications to the product at any time as deemed necessary, while maintaining the same functionalities and intended use • SYKCE guarantees the minimum number of manoeuvres per day, exclusively with the photovoltaic panel positioned correctly and in the conditions as specified in Chapter 3.

PSY24 BATTERY

DESCRIPTION	DATA
Rated voltage:	24 V
Maximum current:	10 W
Rated battery capacity:	20 Ah
Protection rating:	IP 44
Operation temperature:	- 20° C ÷ + 50 °C (0 °C, - +40 °C when charging using the back-up power supply unit connected to the mains)
Complete recharging time:	approx. 15 hours (when charging using the back-up power supply unit connected to the mains)
Dimensions:	258 mm x 235 mm x 180 mm
Weight:	14 kg

Note – The batteries in the PSY24 unit are VRLA (Valve Regulated Lead Acid Batteries). They comply with the specific provision A67 of the IATA/ICAAO regulation governing hazardous goods. PSY24 is therefore not considered hazardous goods and may be transported without any risk by air, sea and on road.

SYP PHOTOVOLTAIC PANEL

DESCRIPTION	DATA
Rated voltage:	24 V
Peak power:	15 Wp
Operation temperature:	-40 °C ÷ +85 °C
Dimensions:	390 mm x 415 mm x 28 mm
Weight:	1,9 kg

Warning – The glass of the photovoltaic panel has been tested to resist to hailstones and medium entity impact. In the event of particularly consistent hail or impact, the glass may be damaged; in this case contact the Nice Technical Assistance service.

EC declaration of conformity

Declaration in accordance with the Directives: 2006/95/EC (LVD) and 2004/108/EC (EMC)

Note: The contents of this declaration correspond to declarations in the official document deposited at the registered offices of Nice S.p.a. and in particular to the last revision available before printing this manual. The text herein has been re-edited for editorial purposes. A copy of the original declaration can be requested from Nice S.p.a. (TV) I.

Declaration number: 285/PSY(...)

Revision: 1

Language: EN

Manufacturer's name: NICE S.p.A.

Address: Via Pezza Alta N°13, 31046 Rustignè di Oderzo (TV) Italy

Type of product: Nice solar kit

Model / Type: SYKCE kit comprises the SYP photovoltaic panel and the PSY24 battery

Accessories: SYA1

The undersigned, Luigi Paro, in the role of Managing Director, declares under his sole responsibility, that the product specified above conforms to the provisions of the following directives:

- Directive 2006/95/EC OF THE EUROPEAN PARLIAMENT AND COUNCIL of 12 December 2006 regarding the approximation of member state legislation related to electrical material destined for use within specific voltage limits, according to the following harmonised standards:
EN 60335-1:2002 + A1:2004 + A11:2004 + A12:2006 + A2:2006 + A13:2008
- DIRECTIVE 2004/108/EC OF THE EUROPEAN PARLIAMENT AND COUNCIL of 15 December 2004 regarding the approximation of member state legislation related to electromagnetic compatibility, repealing directive 89/336/EEC, according to the following standards:
EN 61000-6-2:2005, EN 61000-6-3:2007

Oderzo, 17 March 2010

Ing. Luigi Paro
(Managing director)

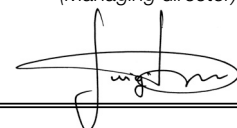

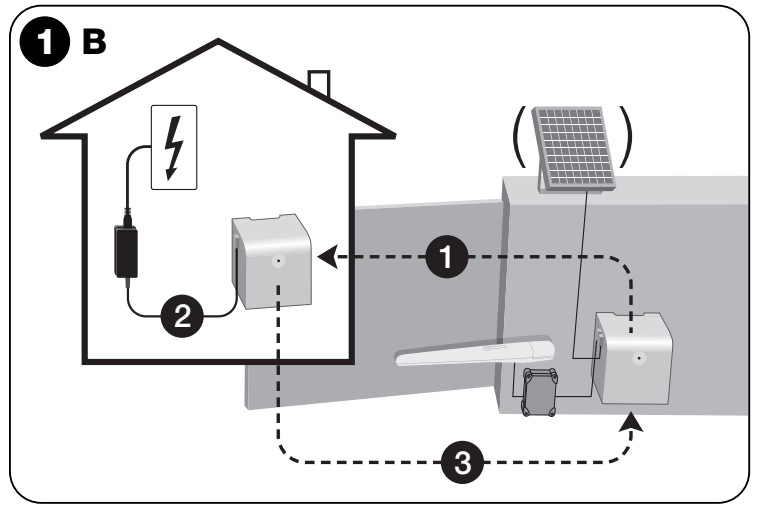
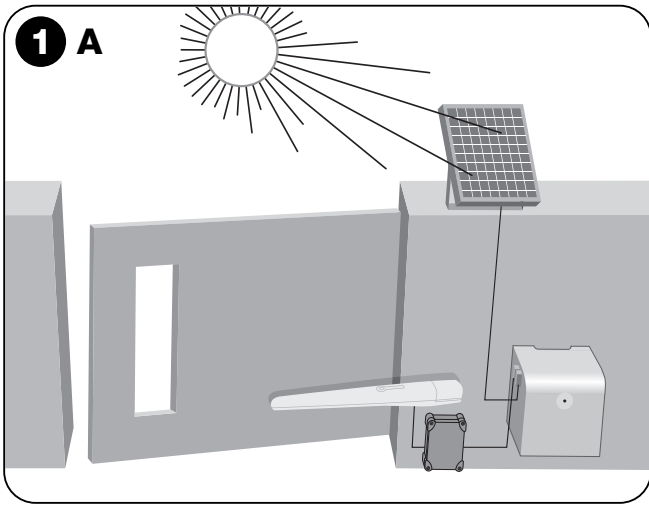

3 EN - Assembly of photovoltaic panel support bracket
 IT - Assemblaggio della staffa di supporto del pannello fotovoltaico
 FR - Assemblage de la patte de support du panneau photovoltaïque
 ES - Ensamblaje del soporte del panel fotovoltaico

DE - Zusammenbau des Haltebügels des Kollektors für Photovoltaik
 PL - Składanie uchwyty mocującego panelu fotoelektrycznego
 NL - Montage van de draagbeugel van het zonnepaneel

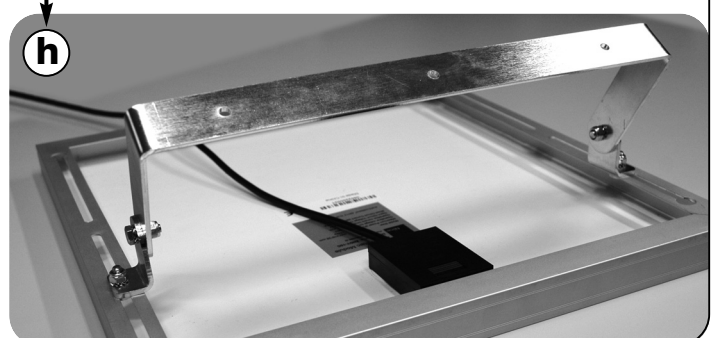
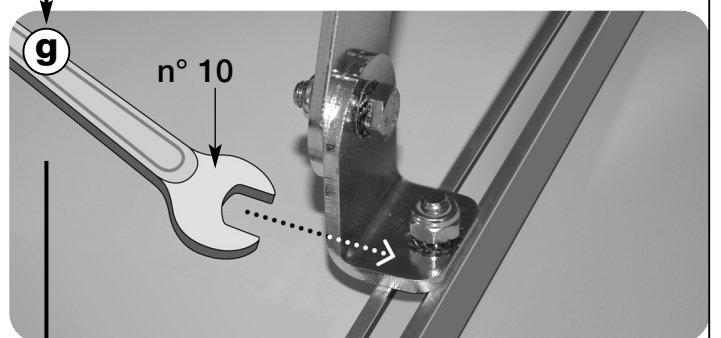
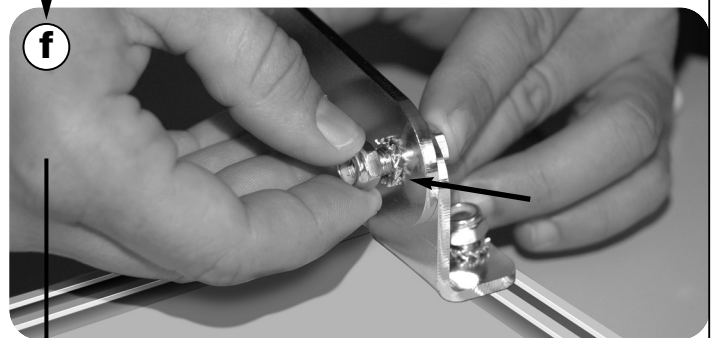
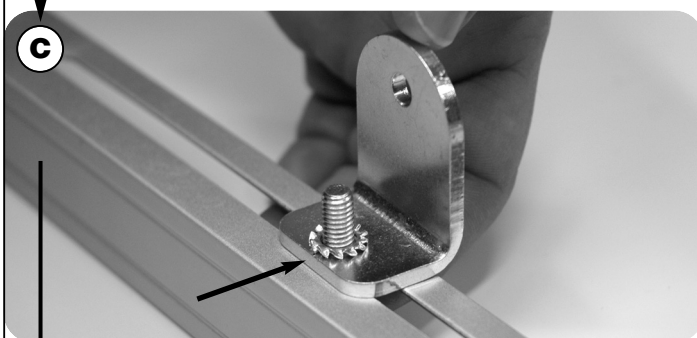
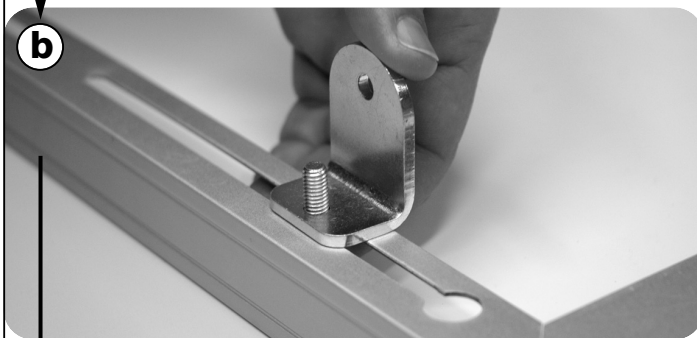
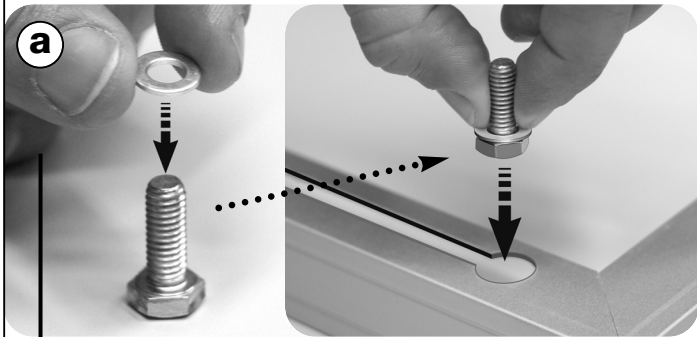

4

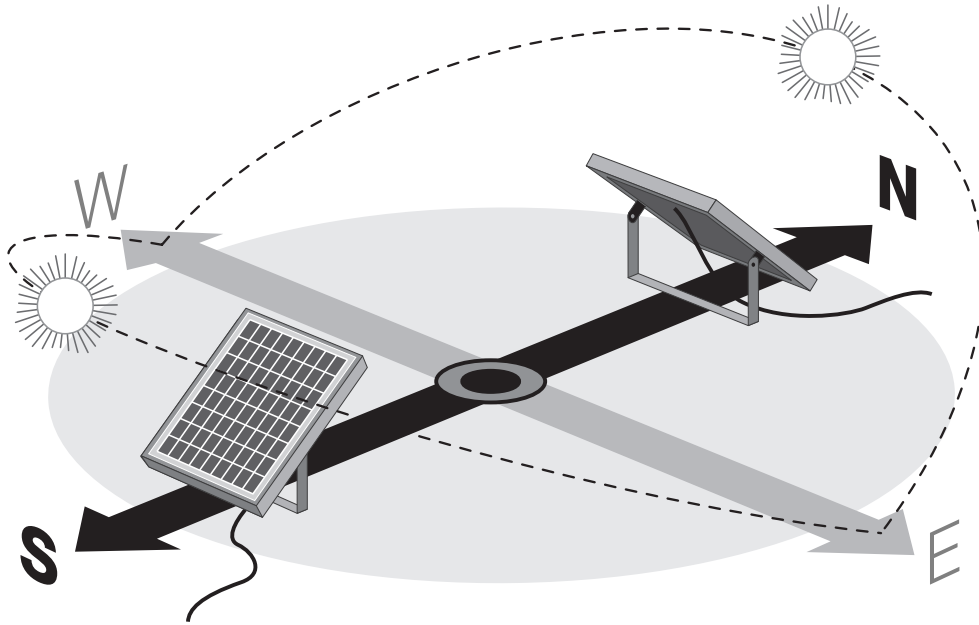

5

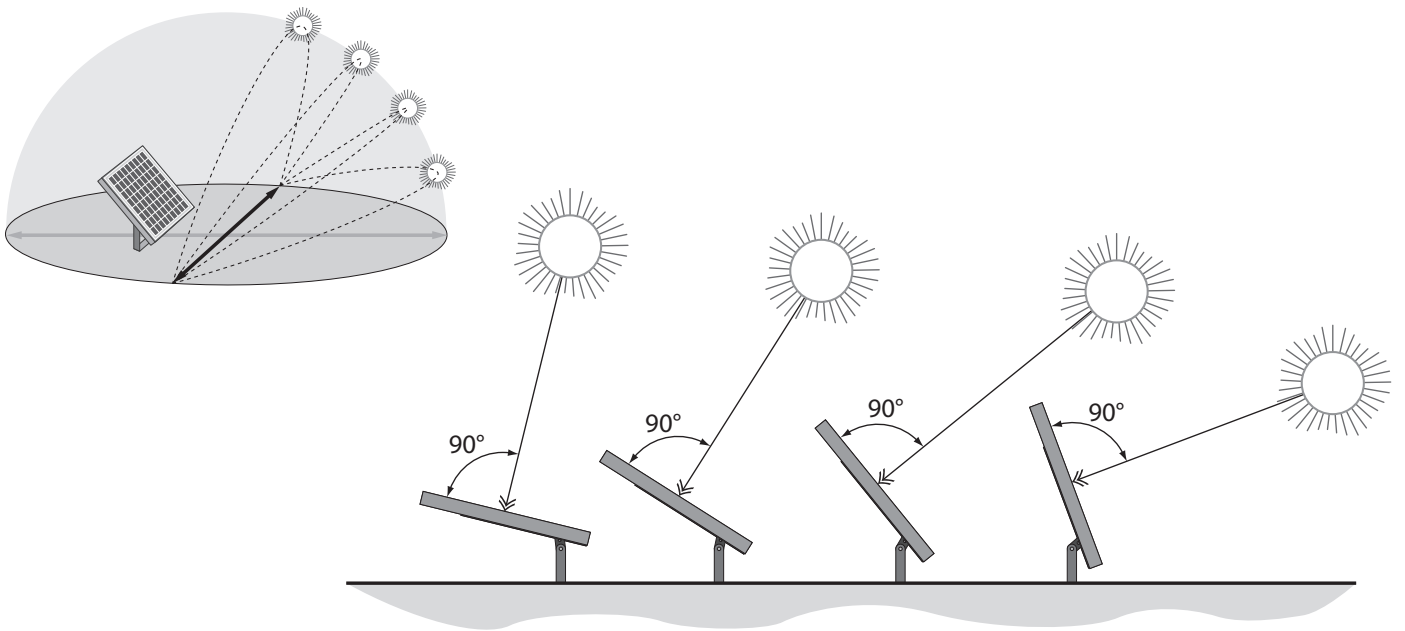

6

